

INNOVATION. PASSION. SUCCESS.

Pressure resistant Control Screening Sieve KTS-VP2

The KTS-VP2 control screener is suitable for all types of pneumatic conveying, one in particular being truck unloading in silos. Adding this to the system guarantees optimum product quality and eliminates production downtimes & product recalls due to high reject rates. It has been specifically designed & built in accordance with the EU Pressure Equipment Directive 2014/68/EU offering the ability to withstand the pressure differences imposed by different processes & applications from -0.5 to 2.0 bar inline at any time.



Standard



Hinged cover for fast cleaning/ screen exchange



Self centering screens with supporting cross for easy & quick screen exchange



Manometer in the cover detects clogging of the mesh cloth



Parts in contact with the product made of stainless steel 1.4301 and glass bead blasting



ATEX certified



According to EC VO 1935 food compliant and FDA suitable

Options



Mobile support for flexible use with motor protection switch



Product safety due to integrated magnetic system



Pharma/Food compliant finish with polished ViwateQ® surfaces.



Customized connection options (Triclamp, Storz or Flange) by means of G4 inch external thread

Your main benefits include ...

- Modular, self-centering system with few replaceable components
- Low maintenance reducing potential product process down time
- Ideal for size restrictive applications due low overall height
- Extremely high achievable throughput
- Optimized and adjusted to allow easy plug & play integration
- Gas-tight design suitable for use within inline vacuum and pressure conveying systems with a range of -0.5 to 2.0 bar
- Built in accordance with the 'Pressure Equipment Directive 2014/68/EU'
- Safe guarding product quality, removing foreign bodies, impurities and agglomerates
- Hinged lid with gas strut support for quick cleaning and easy sieve replacement
- FDA and EC 1935/2004 compliant seals, connecting hoses and sieve screens
- Short lead time availability offered and enabled by our 24h operation

Datasheet

Particle feed sizes:	1 µm – 20 mm
Feed rates:	1 kg/h – 25,000 kg/h
Bulk densities:	200 – 10.000 g/l resp. (l/h)
Mesh openings:	0.5 mm – 20 mm
Mesh cloth material:	Stainless steel wire mesh (diff. materials 1.4301, 1.4401, 1.4016, 1.4462 u.v.m), Plastic mesh
No. of screen decks:	1 per machine
Speed range:	1,500 (1,800) min ⁻¹ at 50 (60) Hz
Screen movement:	High frequency, two dimensional, adjusted according to the product
Acceleration/ Amplitude:	4 – 6 g / 4 – 8 mm
Materials:	Edelstahl und Spezialstahlausführungen, FDA/EU Norm 1935/2004 konforme Gummiwerkstoffe
Surfaces:	High grade surface finish to surface roughness <0.4 µm, ViwateQ® surface treatment
Bestseller:	Milk powder, flours, sugar, pharmaceutical ingredients, powder coatings, plastics, cement and many more.

Dimensions

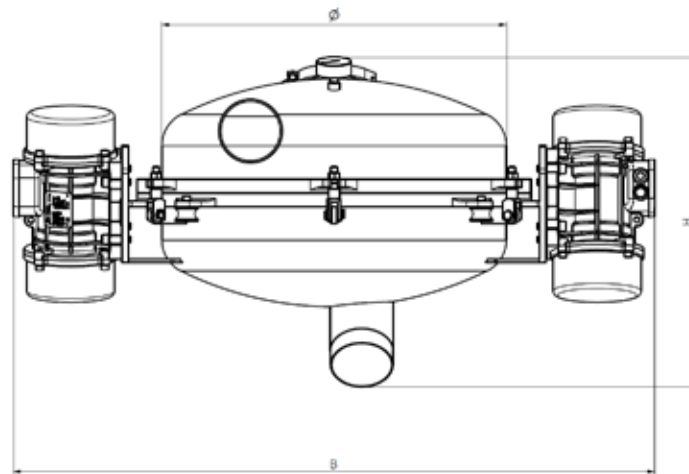

Model sizes KTS-VP2

600

Siebfläche (m ²)	0.3
Width (mm) B Ø	1154
Diameter (mm) Ø	620
Motor power (kW)	0,7
Weight (kg)	132
1 Deck (Height mm) H	594

GKM Siebtechnik GmbH

Felix-Wankel-Straße 11 · 74915 Waibstadt/Germany
Fon +49 (7263) 40972-0 · Fax +49 (7263) 40972-29
info@gkm-net.de · www.gkm-net.de



GKM-SF-01/21