

INNOVATION. PASSION. SUCCESS.

Vibrating Tumbler Screener KTS-V

This screening machine is suitable for all types of dry and wet screening.



Standard

KTS-V 450 – 800



Height adjustable support
(up to KTS-V 800)



Mobile support
(up to KTS-V 800)

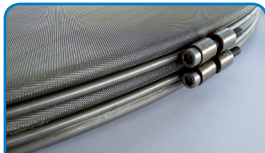

Screen frames with
twin-clamp rings for easy
re-meshing on-site

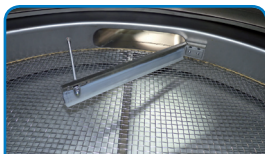

Product contact parts in
stainless steel 1.4301



KTS-VLM 900 – 1500



Options

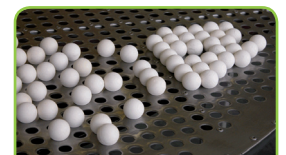

Anti blinding system
Rubber balls



Anti blinding system
Ultrasonic



Anti blinding system
Plastic rings



ATEX
certified 

Your main benefits include ...

- Modular, self-centering, expandable design
- Delivered ready to operate and optimized for each product (Plug & Play)
- Up to 100% availability in 24 h operation
- Up to 4 simultaneous separations on each machine
- 100% dustproof and CE compliant
- Low installation height due to reduced height of intermediate rings
- Easy disassembly and cleaning of all parts
- Robust and lightweight modular design
- Low maintenance
- Very competitively priced with short delivery times

Datasheet

Particle feed sizes:	1 µm – 20 mm
Feed rates:	1 kg/h – 10.000 kg/h
Bulk densities:	200 – 10.000 g/l
Mesh openings:	20 µm – 20 mm
Screens usable:	Stainless steel or plastic wire mesh fabric, perforated plates
No. of screen decks:	1 – 3 per machine
Anti blinding systems:	Rubber balls , plastic rings, Ultrasonic or combinations
Speed range:	1.500 / 3.000 (1.800 / 3.600) min ⁻¹ at 50 (60) Hz
Screen movement:	high frequency, three-dimensional, set to product and capacity
Acceleration/ Amplitude:	3 – 6 g / 3 – 6 mm
Materials:	Stainless steel, special steels, Rubber materials FDA compliant
Surfaces:	ceramic blasted (inside and outside)

Dimensions

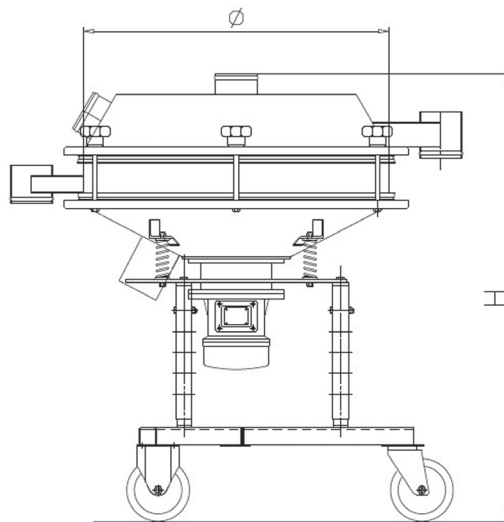

Model sizes KTS-V	450	600	800	900	1200	1500
Screening area (m ²)	0.11	0.27	0.42	0.6	0.93	1.45
Diameter (mm) Ø	455	670	825	1010	1225	1555
Motor power (kW)	0.19	0.24	0.24	0.6	1.20	2.75
Weight (kg)	30 – 40	70 – 85	90 – 105	150 – 200	220 – 250	450 – 520
1 Deck (Height mm) H	775 – 1180*	935 – 1340*	965 – 1165*	830	855	1080
2 Decks (Height mm) H	885 – 1255*	1040 – 1410*	1075 – 1275*	955	1045	1235
3 Decks (Height mm) H	995 – 1330*	1160 – 1495*	1185 – 1385*	1150	1180	1390

* Height adjustable and mobile

GKM Siebtechnik GmbH

Felix-Wankel-Straße 11 · 74915 Waibstadt/Germany
 Fon +49 (7263) 40972-0 · Fax +49 (7263) 40972-29
 info@gkm-group.com · www.gkm-group.com



GKM-SF-02/22